



# Senographe Pristina



GE imagination at work

The Senographe\* Pristina is a full field digital mammography system designed to offer an extensive breast care solution with screening and diagnostic capabilities, focused on an ergonomic design for the technologist and patient comfort.

Senographe Pristina features a 24 x 29 cm detector, designed to offer full breast coverage in a single image. Smaller breasts can also be imaged in any view with paddles that can slide to both sides of the detector.

The Senographe Pristina does not need daily calibration.

## Ergonomics for technologists

- Re-imagined user interface
- Park Positioning during patient positioning
- One touch access to preset rotation for positioning
- Single speed motorized gantry movements
- Sliding compression paddles can move to the side of the detector for compression

## Ergonomics and design for patient comfort

- Designed for Patient comfort
- Wheelchair accessible
- Thinner Bucky than previous platform
- **Rounded edges** detector for patient comfort
- **Self-Compression** device for patient control

## Image quality

- Automatic Optimization of Parameters (AOP) transparently selects all exposure parameters based on breast radiological properties
- Three AOP modes
- eContrast is an image, making automatic adjustments of brightness and contrast

## Smooth digital workflow connectivity

- Automated Quality Control
- Integrated Repeat and Reject Analysis

## Technical Specifications

### Detector

- Detector ready to use right after system boot
- Detector size: 24 x 29 cm
- Pixel size (pitch): 100  $\mu$ m
- Acquisition dynamic range: 14 bits
- Bucky front thickness: 49mm
- Distance between the main column and the edge of the Bucky: 435mm
- Distance between the main column and the beginning of FOV: 411mm

- Image size:
  - LFOV image size)- approx. 13 MB per image
  - Regular image size - approx. 9 MB per image
- Patented needle structure CsI scintillator, single piece construction
- Rounded Edges
- Air cooling

## Tube technology

- X-Ray tube type: Apollon
- Anode target materials - Dual track: Molybdenum (Mo) enriched with Vanadium, and Rhodium (Rh)
- Four focal spots: 0.1 and 0.3 IEC on each target
- Target angle: 0 degree
- Maximal high voltage: 49 kV
- Tube current:
  - Molybdenum target:
    - 100 mA from 25 to 30 kV on large focal spot
    - 40 mA from 25 to 30 kV on small focal spot
  - Rhodium target:
    - 62 mA from 25 to 30 kV on large focal spot
    - 35 mA from 25 to 30 kV on small focal spot
- Anode size (tracks diameter): 100 mm
- Anode heat storage capacity: 250kJ (340 kHU)
- Anode maximum dissipation: 500 W (40 kHU/min)
- Max casing continuous dissipation: 150 W (12 kHU/min) at 40 °C
- Permanent filtration: 0.69 mm Beryllium
- Weight: 7 kg
- X-ray tube assembly: self-encased X-ray tube, oil-free, lead-free, air-cooled head
- Tube protection: software monitoring of tube load

## Grid/breast support

- Universal grid compatible with 2D Conventional Mammography, DBT, CESM and further advanced applications
- Ergonomic breast support designed for patient comfort and cleanability
- Motorized installation and removal of the grid and breast support for geometric magnification
- Breast support material: carbon fiber composite
- Grid ratio: 11:1
- Grid frequency: 67 lines/cm
- Optimized grid motion ensuring no grid structure visible in the image
- Detector to breast support edge-to-edge distance  $\leq$  5 mm

## Automatic exposure

### Automatic Optimization of Parameters (AOP)

#### Fully automatic mode

- AOP is an automatic exposure system that selects all exposure parameters based on radiological density of the breast:
  - track (Mo or Rh)
  - filter (Mo or Ag),
  - kV
  - mAs
- The system identifies the most dense part of the breast to select the appropriate exposure parameters
- Three AOP modes are available:
  - "Standard + ": dose to patient comparable to screen/film mammography
  - "Dose - ": priority is given to dose reduction
  - "Standard": balances low noise and dose reduction
- Automatic acquisition mode for implants

#### Manual mode

- Manual selection of all parameters: track, filter, kV and mAs

## Collimator

- Filters: Molybdenum: 0.030 mm; Silver: 0.030 mm
- Field of View (FOV) in detector plane, in cm:
  - For standard contact views: 24 x 29 maximum FOV or 19 x 23 regular FOV (centered or off-centered left and right), based on the paddle inserted
  - For spot contact views (optional paddles): 13 x 18 - by default when spot paddles are inserted (13 x 21 for off-centered left and right views) and 9 x 9 (9 x 19 for off-centered left and right views)
  - For geometric magnification views (optional): 13 x 23 - by default when magnification platform is installed or 13 x 18, 9 or 9x 9
- Field of View (FOV) selection: automatic and manual
- FOV size: selected automatically based on the paddle or geometric magnification platform used, can be modified manually by using the collimation size switch on the tube head
- FOV location (left, right, center): selected automatically based on the tube arm angle, can be modified manually by using the collimation position switch on the tube head
- Compression and exposure are prevented if the FOV and compression paddle sizes or locations are not consistent
- Light centering device: a light automatically switches on when a preset position is reached, at compression start or at paddle insertion; can be turned on with the collimation switches buttons located on the tube head or on the acquisition console

## Compression

- Compression modes:
  - Motor driven compression up to 20 daN
  - Manual compression possible up to 30 daN
- Dual foot-pedals for column height and compression adjustments
- User defined motorized compression force limit: 4 to 20 daN
- Min force for AOP: 3 daN
- Compression speed: 3 speed levels
- User can select automatic decompression after exposure to minimize patient time under compression

## Self-Compression Device

- Wireless and ergonomic-designed device that allows the patient to compress herself after the technologist has positioned correctly and reached a threshold of compression
- Designed to minimize patient pain and discomfort perception
- Intended to be available for every patient positioning
- Self-compression speed profile is similar to the technologist-controlled one
- It is always possible for the technologist to take compression control even if the patient has started self-compression
- Self-compression is inhibited during acquisition, the patient cannot interfere with the examination

## Positioner

- Isocentric arm with motorized rotation and vertical movement
- Source to image receptor distance: 660 mm
- Floor to image receptor distance: from 65 cm to 150 cm
- Rotation angle: -180/+180 degrees
- Ergonomic handles: two on both sides of the tube arm and two optional handles at the "rear" of the arm

## Safety features

- Gantry motions locked when compression force applied

## User interface

- Four sets of single speed switches for rotation, angulation and lift movements, with an accelerating speed profile
- Four sets of preset position switches for positioning in CC and MLO
- Automatic stop at +/- 90 degrees for lateral positions
- Collimation buttons on the tube head for field of view size and location
- Parameters display
  - Tube arm support rotation angle
  - Compressed breast thickness (in mm)
  - Compression force (in daN)
- Ergonomic control console
  - Controls exposure
  - Provides information on system status
  - Gives access to advanced parameters for system set-up
- Patented automatic view names marking based on breast laterality
- View name can be edited if needed

## Acquisition workstation

- Time to display processed image (average): 14 seconds
- Time between exposures (typical): 12 seconds
- Dose calculated and displayed on the image after every exposure  
(Entrance Skin Dose and Average Glandular Dose)
- Quad core Intel i5 workstation:
  - Memory: 8GB
  - Hard disk: 1 internal 250GB disk for the system
  - Hard disk: 1TB for image storage
  - Ports: 4 Gigabit Ethernet port
  - DVI Display and port connector
- 2 types of display available
  - 1MP LCD Monitor
    - 48 cm (19") medical grade
    - 1280 x 1024 pixels (landscape)
    - High luminance - up to 300 Cd/m<sup>2</sup>
    - Contrast ratio: 2000:1
    - Viewing angle : 170 degrees
    - Mounted on a rotating arm for in-room access
  - 3MP monitor display:
    - High performance color IPS 3MP monitor
    - 54cm (21.2")
    - 2048 x 1536 pixels (landscape)
    - Brightness: 1000 Cd/m<sup>2</sup>
    - Contrast ratio: 1400:1
    - Viewing ratio: 170 degrees
    - Mounted on a rotating arm for in-room access
- Image Presentation  
eContrast allows you to choose among 6 levels to better adapt to breast morphology and radiologist display preferences:
  - eContrast 1 provides a "film-like" aspect with improved visibility of the skin line
  - eContrast 2 to 4 provide increasing steps of image sharpness and contrast
  - eContrast 5 provides a high level of sharpness and contrast, with a very high level of tissue penetration
  - eContrast 6 is adapted to very dense breast or implants
  - Automatic windowing (window level and window width)
  - Other features: zoom, roaming, inversion, flip, rotation of images, window width and level setting, annotations and measurements
- In case of power failure, an Uninterruptible Power Supply (UPS) allows to close the examination without loss of information

## Connectivity

- DICOM\*\* 3.0 platform:
  - Modality Worklist User
  - Storage Provider
  - Storage Commitment User
  - Query/Retrieve User
  - Basic Grayscale Print User
  - Verification Provider
  - DICOM-compliant DVD-/RW and USB Data Interchange

- Connectivity features: customizable Autopush to multiple DICOM databases, Autoprint, Autodelete based on Storage Commitment
- Modality Perform Procedure Step User
- Connectivity to GE Service for remote diagnostic capability
- IHE Profiles: Scheduled workflow, Patient Information Reconciliation, Mammography image, Tomosynthesis profile

## Quality assurance

- Complete quality control program
- Automation of quality control tests: Flat Field, MTF, AOP, SNR
- Test history and results can be reviewed
- Data can be exported for data tracking
- Automated Repeat and Reject Analysis

## Radiation shield

- Choice between two radiation shields:
  - Integrated to the control console
  - Standalone

## High voltage generator

- Generator Integrated into the gantry for room saving
- Generator type: high frequency single-phase power supply
- Ripple: < 4% from peak to peak
- Power: 5 kW max
- mAs range: 2 to 600mAs (depending on track, filter and kV)
- kV range: 22 to 49 kV, in 1 kV steps depending on track
- Generator protection: software monitoring tube load

## Standard configuration

- Motorized isocentric gantry
- X-ray tube with rotating Mo/Rh anode
- 24 x 29 cm flat panel detector
- Acquisition workstation
  - DVD-/RW
  - 1MP or 3MP display
  - Control console
  - UPS
- Pair of dual foot-pedals
- High-frequency generator
- Face shield
- 24 x 29 cm bucky with grid
- 24 x 29 cm paddle
- 19 x 23 cm sliding paddle
- 1.5 and 1.8 magnification stands
- Quality control toolkit
- User manual and technical documentation

## Options

- 24 x 29 cm ergonomic paddle
- 19 x 23 cm ergonomic sliding paddle
- 24X29cm Flexible Compression Paddle
- 19X23cm Flexible & Sliding Compression Paddle
- 10x23 Sliding Implant/Small Breast Compression Paddle
- Square spot sliding compression paddle
- Round spot sliding compression paddle
- 2D localizer with standard and round spot biopsy paddles
- 2D localizer Swiss Cheese compression paddle
- Bar code reader
- X-Ray protective shield
- Self-Compression Device
- Upgradable to Senographe Pristina 3D
- Upgradable to SenoBright HD

## Senographe Pristina 3D

Senographe Pristina 3D is a three-dimensional imaging technology that uses a low dose short X-ray sweep around a compressed breast. The acquired projection images are processed electronically in order to reconstruct a 3D representation of the entire breast. This imaging technique is designed to separate the tissues and to reduce the overlapping of structures, which represents a limiting factor in standard 2D mammography.

The 3D option is available for the Senographe Pristina platform that generates 3D and 2D images.

### Senographe Pristina 3D Technology

- Sweep angle is 25° with 9 projections at any rotation angle between -90° and +90°
- The “Step and Shoot” tube motion stops for each exposure to avoid image blur
- Mo and Rh tube tracks create very narrow x-ray spectra, exactly where the dose efficiency is for thin (Mo) and medium and thick breasts (Rh)
- Detector: 100 microns with no binning
- Automatic reconstruction of the images by using **ASIR<sup>DBT</sup>** iterative algorithms
- The dose of a DBT view is designed to be equivalent to the dose of a 2D standard acquisition of the same view
- Capability to reconstruct 0.5mm and 1mm distance between tomo-planes

## SenoBright HD

The SenoBright HD (Contrast Enhanced Spectral Mammography CESM) application shall enable contrast heightened breast imaging using a dual energy technique. This imaging technique can be used as an adjunct following mammography and ultrasound exams to localize a known or suspected lesion.

### Patient Comfort

- As with our standard mammography systems, patients lying in a recumbent position can be examined with SenoBright HD

### Ergonomics designed for technologist

- User can switch between standard mammography and Spectral Mammography mode
- SenoBright HD provides a timer function to both monitor and record time after injection, which is displayed as an annotated field in the images
- SenoBright HD offers Automatic Optimization of Parameters (AOP) and manual exposure modes for the dual-energy exam
- SenoBright HD will automatically acquire the Spectral Mammography images for each view with a single action of the x-ray exposure control

### Technology

SenoBright HD chooses filtering materials depending on the operating mode and the exposure levels necessary. For the high-energy acquisition, a proprietary multi-layer filter is used to shape the resulting energies of the x-ray spectrum to those required to best highlight iodine.

### Energy Levels

The energy levels may vary depending on the breast thickness of every patient

- 26-34 KVp for lower energy acquisition
- 49 KVp for higher energy acquisition.

### System Power supply

- Input frequency: 50Hz/60Hz
- Input voltage: single-phase 200/208/220/240 V~
- APC Smart-UPS 750 VA

### System Weight

- Gantry: 394 kg
- Control Station without monitors: 198 kg

### Environmental conditions

- Temperature range: 15° to 30°C
- Humidity range: 10% to 80%
- Atmospheric pressure range: 70 kPa to 106kPa (0 to 3000m altitude)

# Senographe Pristina

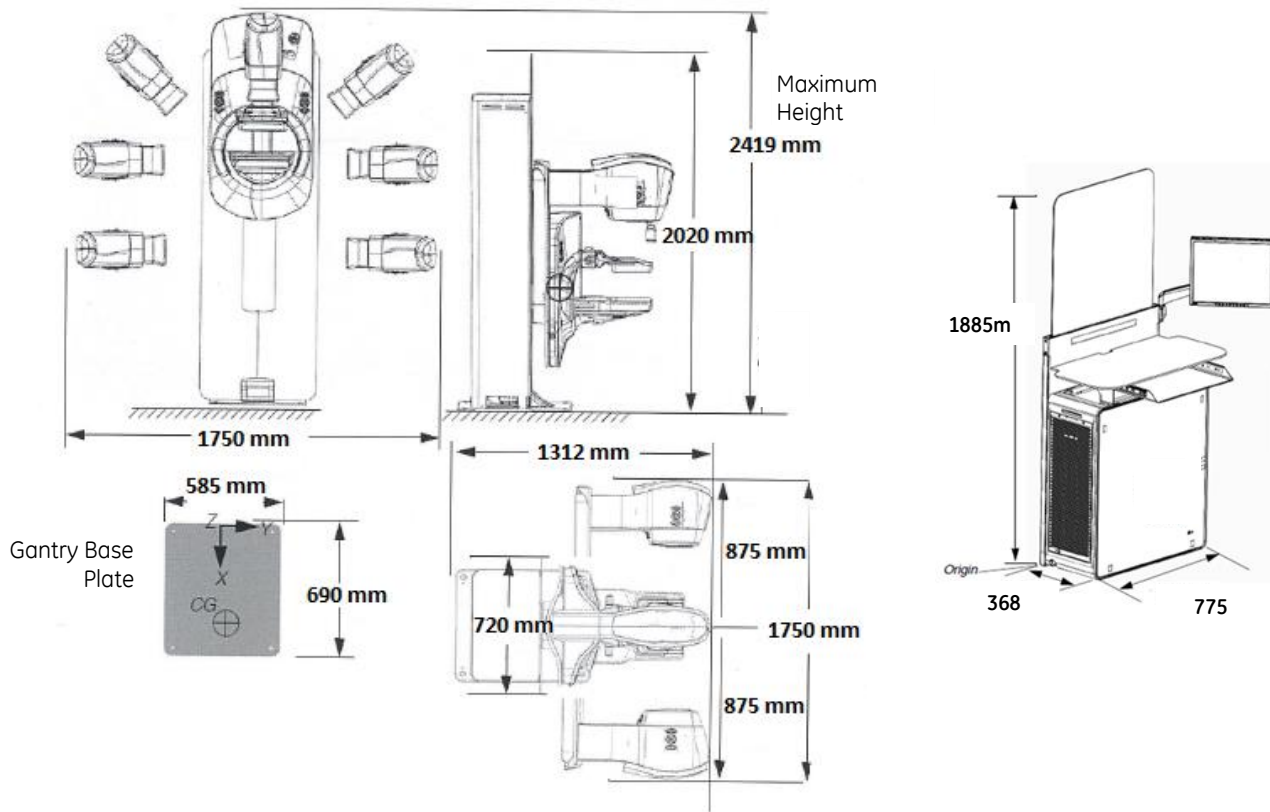

**NOTE:**

- Weights and dimensions should be mentioned as non-contractual values because they vary slightly with configurations and equipment evolutions.

Senographe Pristina it is not available in all countries. Please refer to your Sales representative.

GE Healthcare  
 Chalfont St.Giles,  
 Buckinghamshire,  
 UK  
[www.gehealthcare.com](http://www.gehealthcare.com)

Data subject to change.  
 Marketing Communications GE Medical Systems  
 Société en Commandite Simple au capital de 85.418.040 Euros  
 283, rue de la Minière, 78530 Buc France  
 RCS Versailles B 315 013 359  
 A General Electric company, doing business as GE Healthcare

UK: 0800 0329201	Spain: 0900 993620
Germany: 0800 1890461	France: 0800 908719
Austria: 0800 291888	Switzerland
Italy: 0800 786947	German: 0800 837279
	French: 0800 837279

GE, the GE Monogram, and imagination at work are trademarks of the General Electric Company

\*Trademark of General Electric Company

\*\* DICOM is a trademark of National Electrical Manufacturers Association.

. All other trademarks, service marks, company names and product names are the property of their respective owners

© 2016 Copyright GE Healthcare



GE imagination at work



Работайте с лучшими,  
всё остальное компромисс!

---

**8 (800) 775-10-98**

**medliga.ru**